

DRG.No. 984C-200
 USED ON
 984C-000

NOTE: THE 984 MKIII AS SHOWN REPLACES THE PREVIOUS VERSIONS
 ALTHOUGH MOST SIZES REMAIN THE SAME SOME SIZES HAVE CHANGED
 (ALL PREVIOUS JIGS AND TEMPLATES MUST BE CHECKED AND MODIFIED)

DRAWN TO B.S. 308

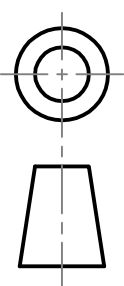

THIRD ANGLE PROJECTION

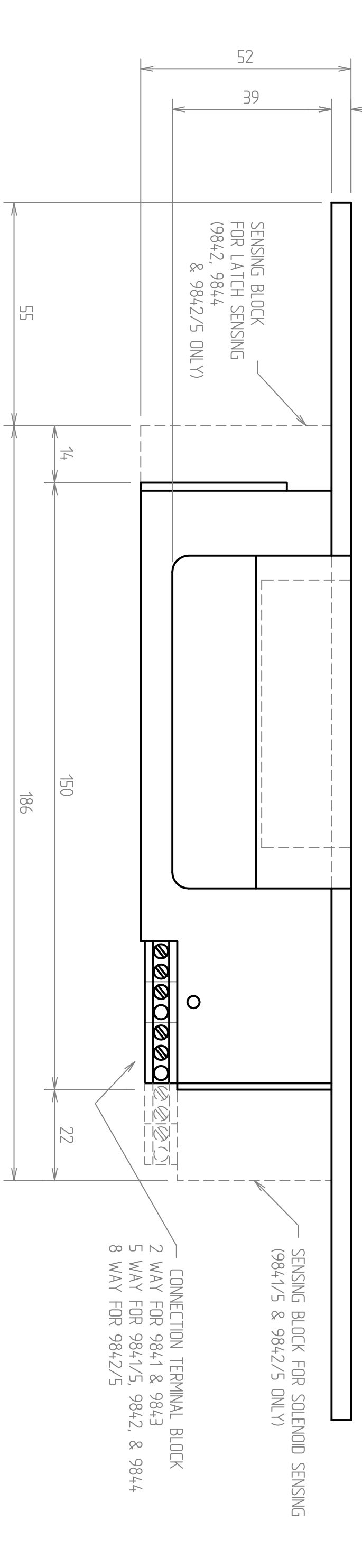
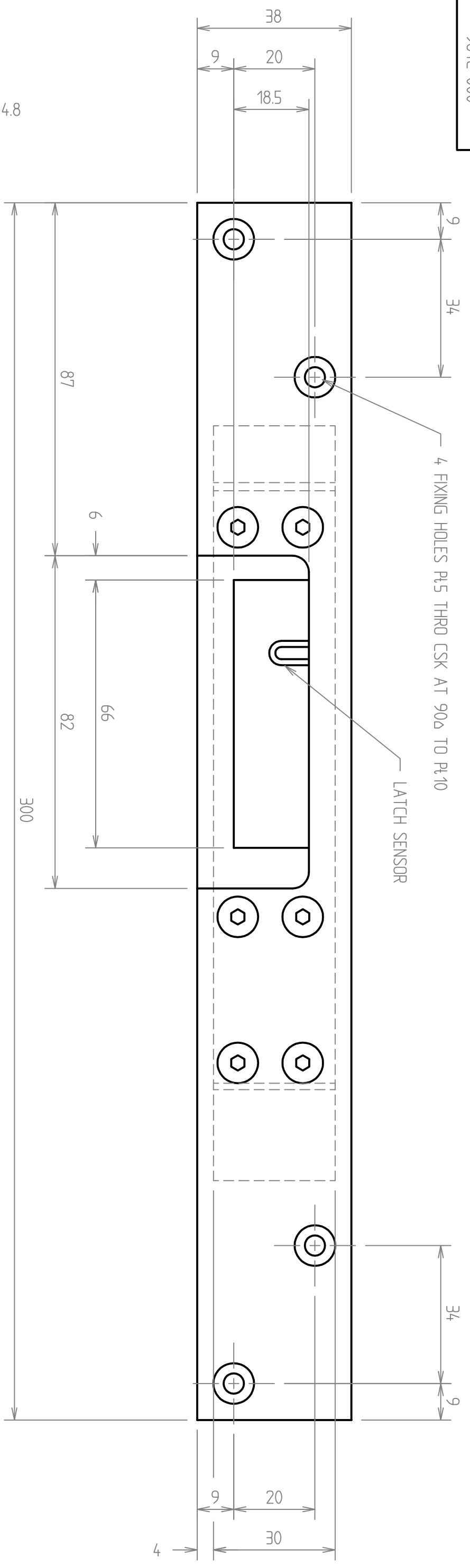

NOTE: CLARKE INSTRUMENTS LIMITED RESERVE THE RIGHT TO MODIFY THE DESIGN WITHOUT NOTICE

PROTECTIVE FINISH		-	
TOLERANCES FOR DIMENSIONS		DIMS. SHOWN THUS 1. 00.4 DIMS. SHOWN THUS 10. 00.15 DIMS. SHOWN THUS 150. 00.05 UNLESS OTHERWISE STATED	
MATERIAL		-	
STORES REF.		-	
<h1>Clarke Instruments Ltd.</h1>		DRG.No.	984C-200
		TITLE	TYPE 984 MKIII SALES ILLUSTRATION
ISSUE	DATE	CHANGE NOTE	ISSUE
A	16-11-94	-	
DRAWN	ART.	CHECKED	CERTD.
SCALE		1:1	